

**INJECTION MOLDED 45° BEND
4" - 12" DIAMETER**

PART #	PIPE SIZE	A	JOINT
0494ST	4 in (100 mm)	1.3 in (33 mm)	ST
0494WT	4 in (100 mm)	1.3 in (33 mm)	WT
0694ST	6 in (150 mm)	1.8 in (46 mm)	ST
0694WT	6 in (150 mm)	1.8 in (46 mm)	WT
0894ST	8 in (200 mm)	2.4 in (60 mm)	ST
0894WT	8 in (200 mm)	2.4 in (60 mm)	WT
1094ST	10 in (250 mm)	3.4 in (87 mm)	ST
1094WT	10 in (250 mm)	3.4 in (87 mm)	WT
1294ST	12 in (300 mm)	4.4 in (112 mm)	ST
1294WT	12 in (300 mm)	4.4 in (112 mm)	WT

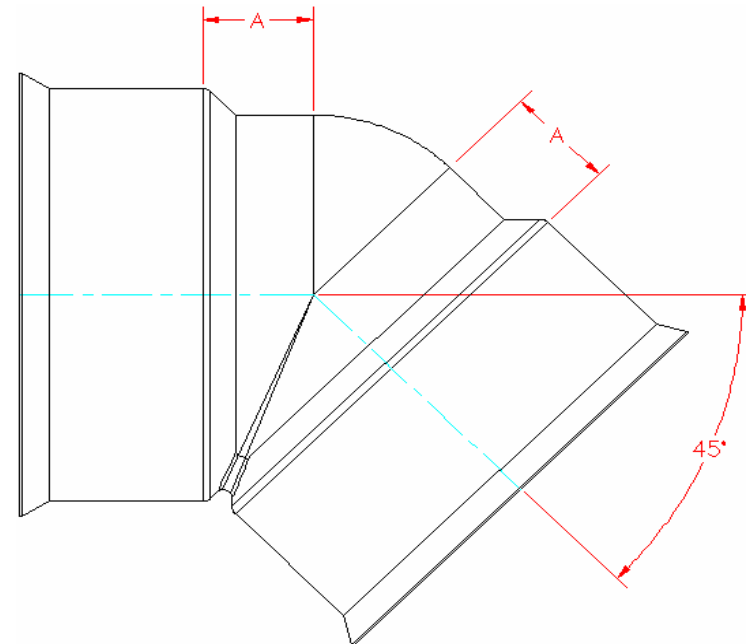

NOTE:

FITTINGS WHOSE PART NUMBERS END WITH "WT" HAVE WATER TIGHT BELL CONNECTIONS. WATER TIGHT BELLS ARE SHOWN HERE IN THIS DRAWING AND REQUIRE GASKETS TO BE FITTED TO DUAL WALL PIPE TO FORM A WATER TIGHT JOINT. (GASKETS INCLUDED)

FITTINGS WHOSE PART NUMBERS END WITH "ST" HAVE SOIL TIGHT BELL CONNECTIONS. SOIL TIGHT BELLS HAVE MOLDED CLEATS AND REQUIRE NO GASKET TO MAKE CONNECTION TO DUAL WALL PIPE.

NOTE: ALL FITTINGS DIMENSIONS ARE FOR REFERENCE ONLY

 ADVANCED DRAINAGE SYSTEMS, INC.	DRAWING #:	3200	
	DRAWN BY:	JCB	07.31.06
	APPROVED BY:		
	REVISIONS:	NJP	06.15.07